

Application Note

Measurements of Dielectric Constant and Loss

IET Labs 7600 Series LCR Meter & the Dielectric Products Type LD-3 Cell

This application note describes an integrated system for dielectric measurements on solid and liquid materials that includes the measurement instrument, the test cell, and the connecting cables and adapters. This setup allows rapid, precise measurements over a wide frequency range. The necessary Dielectric Cell, cables, adapters and the 7600 Plus Series LCR Meter are all available from IET Labs.

The complete assembly is shown in the photograph in Figure 1. The shielded terminal of the LD-3 cell fixed electrode should be connected to the low terminals of the meter, both H_L and P_L , by means of the shielded cables, a Tee and GR-874 adapter (see photograph). The cable shields provide a ground to the body of the cell. The unshielded terminal on the barrel of the cell should be connected to the high terminals of the meter, I_H and P_H , with cables, a Tee and the banana pin adapter. The base plate keeps the cables from moving while the measurements are made which is particularly important at higher frequencies.



Figure1: IET Labs 7600 Precision LCR Meter connected to Dielectric Products LD-3 Cell

Procedures

Calibration - The 7000 Series instrument should have had a full calibration within its 1 year calibration interval. It should have a new OPEN circuit calibration performed, which, for best accuracy, be made at



Application Note

the test frequency to be used. To do this, remove the I_H and P_H leads from the cell (but keep them connected together) and move them a few inches from the H cell terminal, shielded from it by the body of the cell. The OPEN calibration should be performed using the procedure in the Operating Instructions for the 7000 Series instrument used.

A new SHORT circuit zero should also be made. Simply plug the H plug (carefully) into the L connector and make the SHORT calibration.

Procedure (See Measurement Methods) - These dielectric measurements require a series of two or more capacitance and dissipation factor measurements from which the relative dielectric constant (K or ϵ_r) and dissipation factor (D) of the sample can be calculated. The procedures are outlined on the following pages along with their formulas. Further information on these measurements is available in ASTM Standard D-150 and IEC Standard 250.

Accuracy - The accuracy of the measurements of dielectric properties depends on the procedures used, the two-fluid method being most accurate, and on the accuracy of the separate capacitance and dissipation factor measurements. The latter depend on the test conditions as shown in the operation instructions for the instrument used but may be substantially better than the specifications given, particularly if calibrations are made at the test frequency to be used and if several measurements are averaged to increase precision.



Application Note

Definitions

Many different notations are used for dielectric properties, see references above. This application note will use **K**, the relative dielectric constant, and **D**, the dissipation factor (or $\tan \delta$) defined as follows:

$$K = \varepsilon_r' = \varepsilon_r \quad \text{and} \quad D = \tan \delta = \varepsilon_r'' / \varepsilon_r'$$

The complex relative permittivity is

$$\varepsilon_r^* = \varepsilon / \varepsilon_0 = \varepsilon_r' - j\varepsilon_r''$$

where ε_0 is the permittivity of a vacuum, and ε the absolute permittivity.

$$\varepsilon_0 = 0.08854 \text{ pF/cm}$$

The capacitance of a parallel-plate air capacitor (two plates) is

$$C = K_a \varepsilon_0 \text{Area} / \text{spacing}$$

where K_a is the dielectric constant of air

$$K_a = 1.00053$$

if the air is dry and at normal atmospheric pressure.

Permittivity (ε) is the dielectric constant multiplied by the dielectric constant of empty space (ε_0), where the permittivity of empty space (ε_0) is a constant appearing in Coulomb's Law, having a value of 1 in centimeter-gram-second electrostatic units, and of 8.854×10^{-12} farad/meter in rationalized meter-kilogram-second units.*

A Dielectric is a material which is an electrical insulator or in which an electric field can be sustained with a minimum dissipation of power.*

Dielectric Constant of a material is defined in electrical terms for an isotropic medium, as the ratio of the capacitance of a capacitor filled with a given dielectric to that of the same capacitor having only a vacuum as a dielectric.*

* McGraw-Hill Dictionary of Scientific and Technical Terms, 1974 McGraw-Hill, Inc



Application Note

Measurement Methods: Solids

The Contacting Electrode Method is quick and easy, but is the least accurate. The results for K should be within 10% if the sample is reasonably flat.

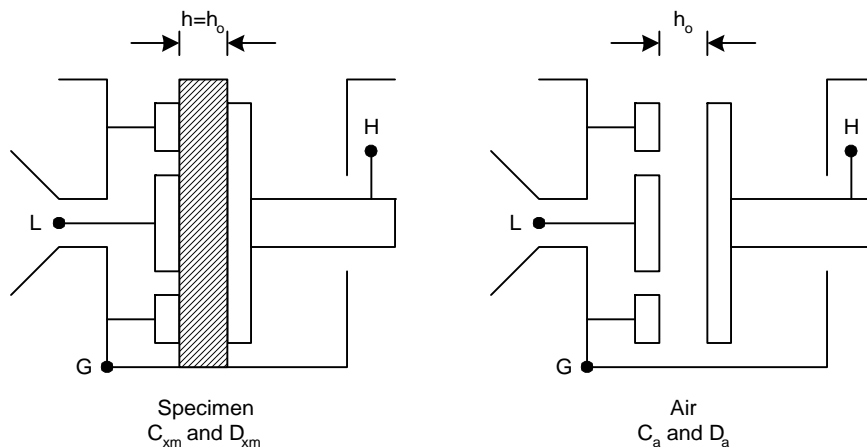

Figure 2: Contact Method

First the sample is inserted in the cell and the electrodes closed with the micrometer until they just touch the sample. **Do not force the electrodes against the sample.** Turn the micrometer with a light finger touch. Record the electrometer setting as h_m . Set the instrument to measure *parallel* capacitance and measure the capacitance and dissipation factor of the sample as C_{xm} and D_{xm} .

Open the electrodes and remove the sample. Then close the electrodes to the same micrometer reading, h_m . Measure C (parallel) and D of empty cell as C_a and D_a .

Calculate K_x and D_x of the sample from:

$$K_x = (1.0005) C_{xm}/C_a \quad \text{and} \quad D_x = D_{xm} - D_a$$

The factor 1.0005 in the formula for K_x corrects for the dielectric constant of (dry) air. Subtracting D_a from D_{xm} removes any constant phase error in the instrument. For even better D accuracy, adjust the electrode spacing until the measured capacitance is approximately equal to C_{xm} and then measure D_a .

Note that both K_x and D_x will probably be too low because there is always some air between the electrodes and the sample. This error is smallest for very flat samples, for thicker samples and for those with low K and D values.

Application Note

Air Gap Method

The Air-Gap Method avoids the error due to the air layer but requires that the thickness of the sample is known. Its thickness should be measured at several points over its area and the measured values should be averaged to get the thickness h . The micrometer used should have the same units as those of the micrometer on the cell.

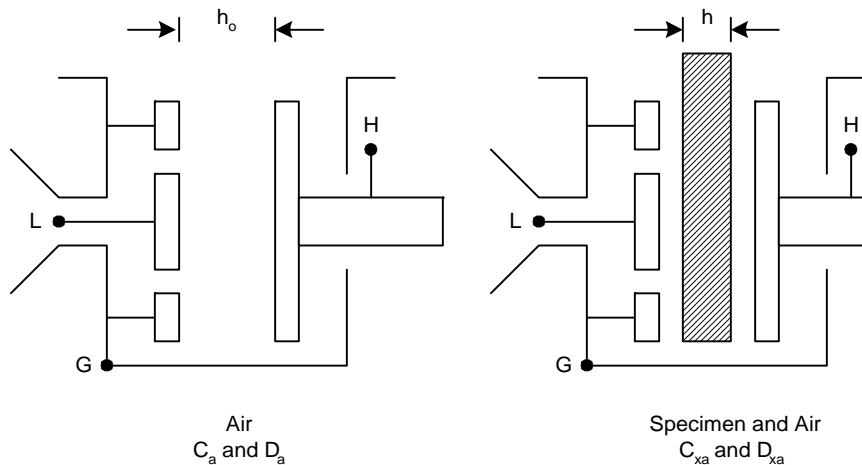

Figure 3: Air Gap Method

Set the electrodes to about .02 cm or .01 inch greater than the sample thickness, h , and measure the equivalent *series* capacitance and D , as C_a and D_a . Note the micrometer setting as h_m and correct this with the micrometer zero calibration, h_{m0} (see Appendix A), to get

$$h_o = h_m + h_{m0}$$

Then insert the sample and measure it as C_{xa} and D_{xa} . Calculate

$$M = (h_o - h)/h_o$$

$$D_x = (D_{xa} - D_a) \left(\frac{C_a}{C_a - MC_{xa}} \right)$$

and

$$K_x = \left(\frac{(1 - M)C_{xa}}{C_a - MC_{xa}} \right) \left(\frac{1.0005}{1 + D_x^2} \right)$$

Application Note

The factor $(1 + D_x^2)$ converts the series value of C_x to the equivalent parallel value and is not necessary if D_x is small. The factor of 1.0005 corrects for the dielectric constant of air (if dry). The formula for D_x assumes that the true D of air is zero and it makes a correction for a constant D error in the instrument.



Application Note

The Two Fluid Method

The Two-Fluid Method is preferred for specimens whose thickness is difficult to measure and for best accuracy which will be limited by the accuracy of the C and D measurements. However it requires four measurements, two using a second fluid (the first being air). The dielectric properties of this fluid need not be known, but it must not react with the specimen and it must be stable and safe to use. A silicone fluid such as Dow Corning 200, 1 centistoke viscosity, is most generally satisfactory.

The four measurements of *series* capacitance and D are outlined in the figure below. Note the spacing is the same for all measurements and should be just slightly more than the specimen thickness. The accuracy will be limited mainly by the accuracy of the measurements made.

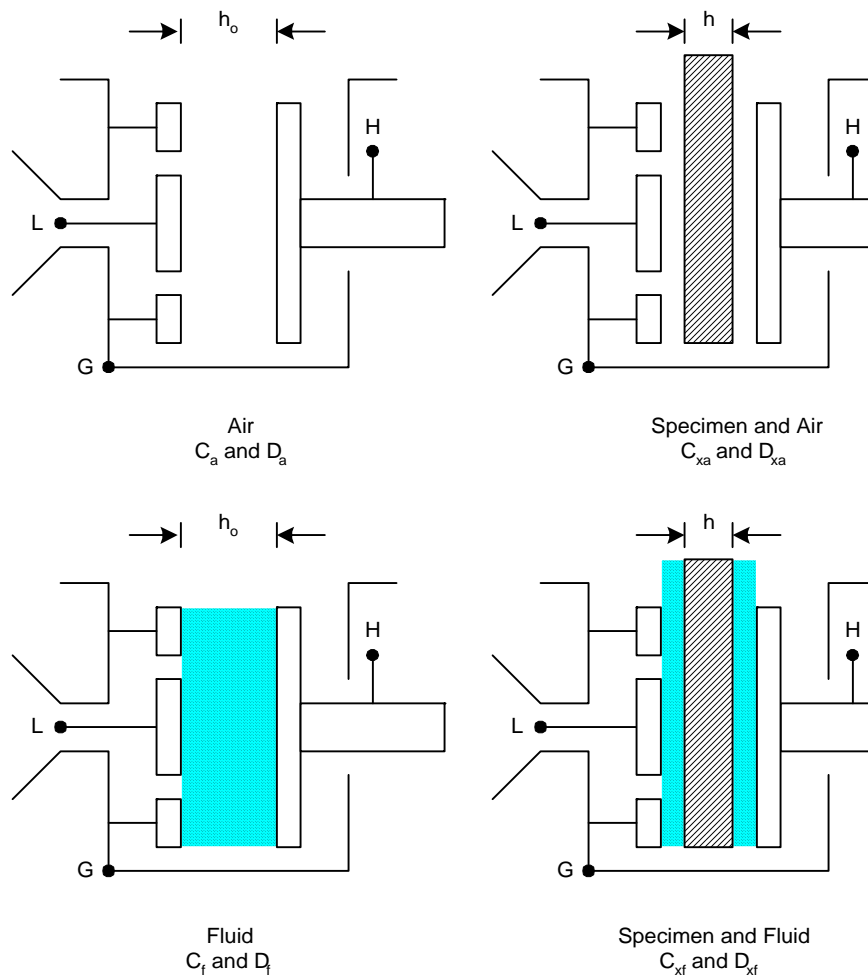

Figure 4: Two-Fluid Method

Application Note

Two Fluid Calculations

From these measurements calculate

$$\frac{h}{h_o} = 1 - \frac{C_a C_f (C_{xf} - C_{xa})}{C_{xa} C_{xf} (C_f - C_a)} \quad \text{and} \quad \frac{C_{xser}}{C_a} = \frac{C_{xf} C_{xa} (C_f - C_a)}{C_a (C_{xa} C_f - C_{xf} C_a)}$$

which is the ratio of the equivalent series capacitance of the sample to C_a . If D_x is close to D_f or larger use

$$D_x = D_{xf} + \frac{C_a (C_{xf} - C_{xa}) (D_{xf} - D_f)}{C_{xa} C_f - C_{xf} C_a}$$

If D_x is very small use

$$D_x = \frac{(D_{xa} - D_a) C_{xf} (C_f - C_a)}{C_{xa} C_f - C_{xf} C_a}$$

which makes a zero D correction.

From the above results calculate

$$K_x = \left(\frac{h}{h_o} \right) \left(\frac{C_{xser}}{C_a} \right) \left(\frac{1.0005}{1 + D_x^2} \right)$$

As before, the factor of 1.0005 corrects for the dielectric constant of air (if dry) and the $(1 + D_x^2)$ factor converts C_x to equivalent parallel capacitance.

Measurement Methods: Liquids

Measurements on liquids are simple, the only difficulty is with handling and cleanup. Measure equivalent *parallel* capacitance and D first of air (C_a and D_a) and then of the liquid to be measured (C_{xm} and D_{xm}), then determine

$$K_x = \frac{C_{xm}}{C_a} (1.0005)$$

and

$$D_x = D_{xm} - D_a$$

Application Note

Note that the spacing is not critical but should be narrow enough to make the capacitance large enough to be measured accurately.

Other liquid cells are available that are easier to clean and use a smaller sample (as listed in Appendix B).

Appendices

Appendix A: Micrometer Zero Calibration

The micrometer zero correction may change with used. To check this, measure the capacitance of the empty cell with a narrow setting, h_1 , getting C_1 , and with a wider setting, h_2 , getting C_2 . The value of the zero offset, h_{mo} , is

$$h_{mo} = \frac{h_2 C_2 - h_1 C_1}{C_1 - C_2}$$

Greater accuracy is obtained by taking measurements at more spacings and averaging the results.

Appendix B: Accessories

Available from IET Labs Inc.

- Interface Cable Set
- High Temperature Cell LD-3T
- High temperature Cable Set
- Teflon standard TS-100
- Liquid Cell 350
- Powder and Paste Cell MC-100
- Resistivity Cell RF-100

For complete product specifications on the 7600 Plus Series Precision LCR meters or any of IET Labs's products, visit us at www.ietlabs.com. Do you have an application specific testing need? Email your questions to sales@IETLabs.com.

